

MEN'S PANTS

SEWING PANTS WITH SIMPLE FLY

INSIDE 

OUTSIDE 

NOTE that the outside of the pants is marked as grey and the inside of the pants as white on the explanatory pictures.

FRONT AND BACK PIECE

Sew the tucks in the back piece.

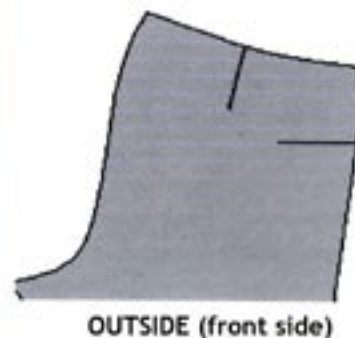
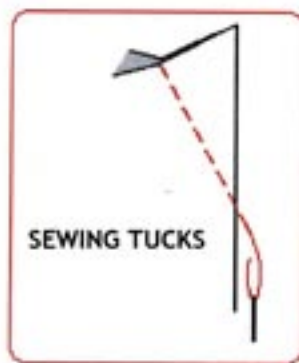
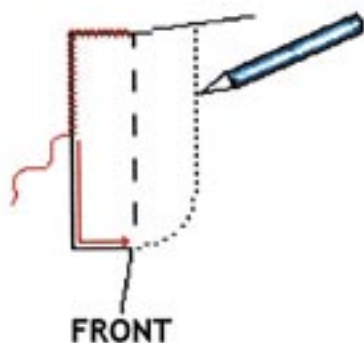

On the front piece sew zigzag stitch over the edges of both flaps (separately, not together) and using a removable pencil or dress makers chalk, mark the curve on the front of the left hand side.

SEW LEGS

Line up the sides of front and back pieces, right sides facing in, and sew side leg seam. Do this for both legs. Line up the inside leg sides and sew together. Press seam open. Do this for both legs.

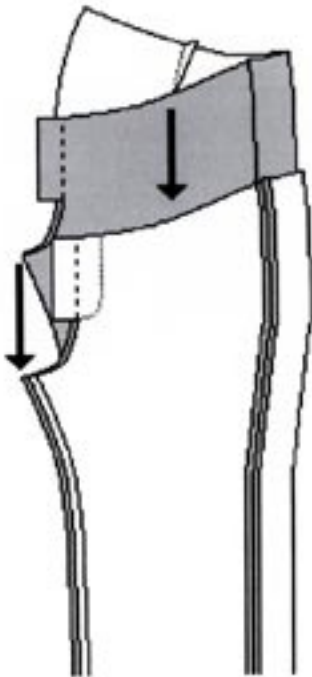
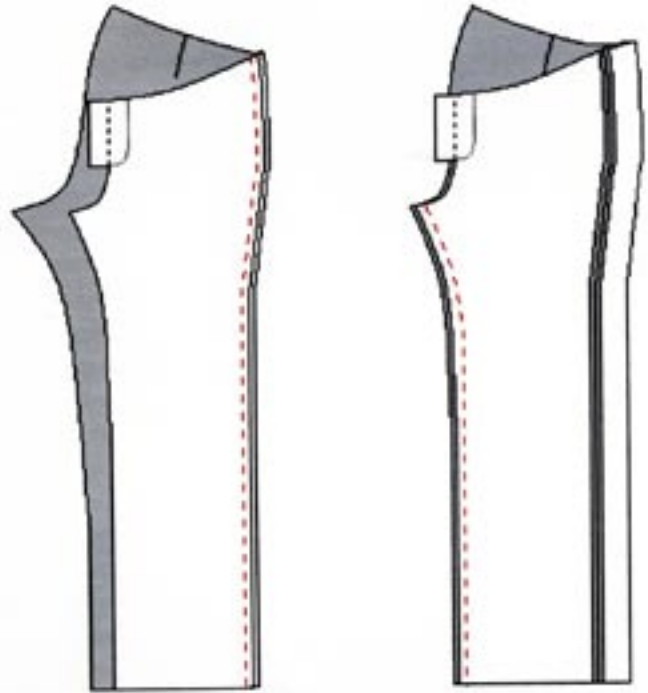

Leave one leg with wrong sides facing out, and turn the other leg so that the right sides are facing out. Put the right side out leg into the other leg, lining up the crotch seam.

SEW FLY

With legs lined up inside each other, sew the front crotch.

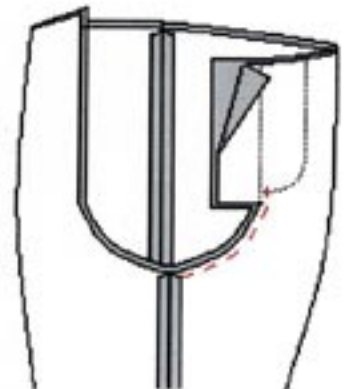

Then by pressing the seam, and following the line, press and HAND stitch the flaps so that the left side overlaps the right side.

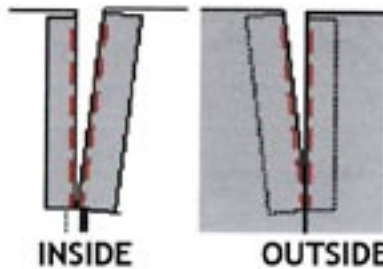

Turn the pants to the outside and attach the zip on the right side.



Then, close the overlapping flaps and pin together.

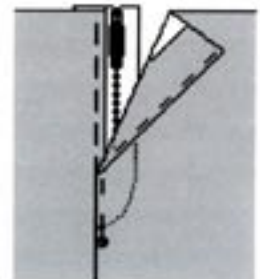

Turn the pants to the inside and carefully open the flaps (you should have the remaining 'unattached' flap to the left side with zip pinned to its top). Make sure you do not dislodge the pins on the outside. Attach the zip to the SINGLE layer of the left flap.

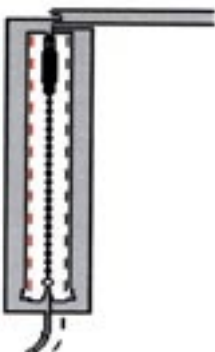

The zip is now attached to the right side of the front piece (including right flap) and the left flap of the fly.

Turn pants to the outside again and overstretch the curved line to join the flaps and give the fly its style.

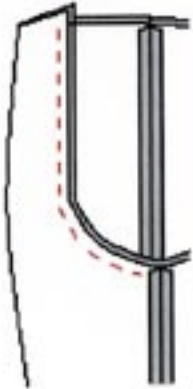

Finally, finish sewing the back seam of the crotch.

WAISTBAND

Fold and press as shown

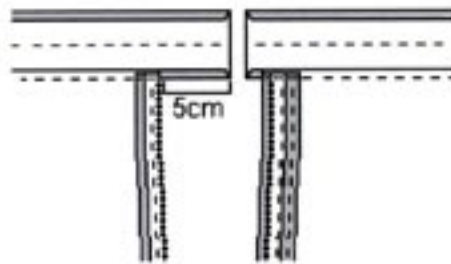
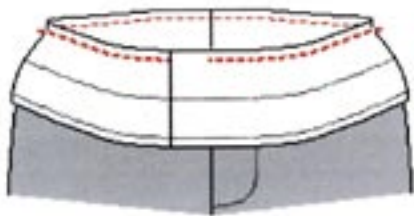
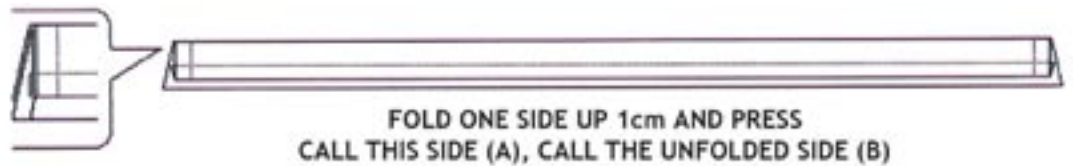

Attach the unfolded side (B) edge to the top of the pants, right sides of the fabric facing each other. Make sure that the 5 cm overlap is on the left side. Stitch on.

Fold up the waistband and press seams up towards the waistband.

Fold waistband right sides together and sew edges.

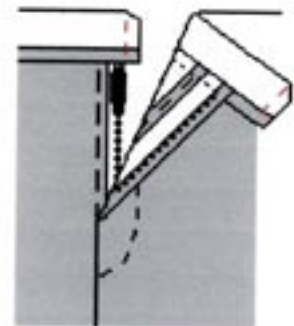
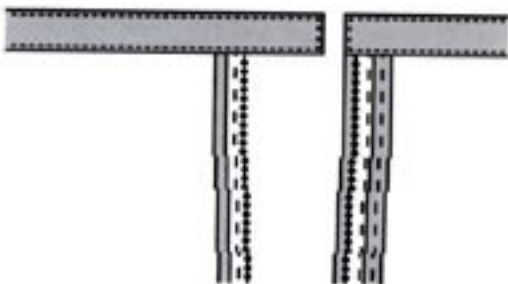

Then turn right side out and press well, being sure to pull out the corners. NOTE! Corners are shown cut in the picture but you should cut the corners AFTER you have sewn the edge. Top stitch over waistband, joining it totally to the pants.

CUFFS

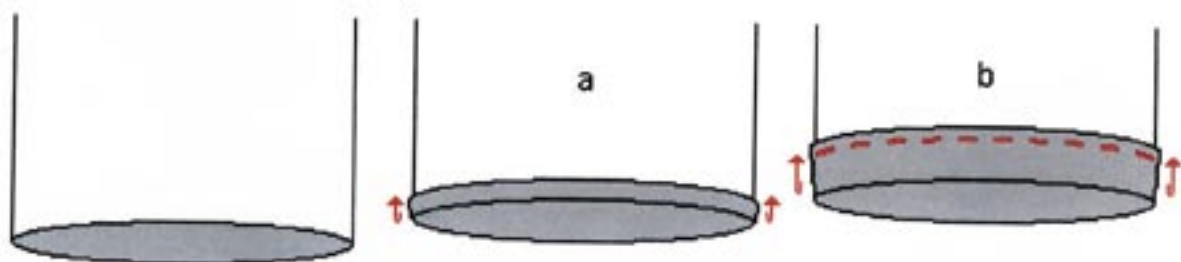

- a) Fold up a small edge of around 1 cm and press.
- b) Fold up a larger edge, of around 1,5-2 cm, press and sew.

The sewing instructions for the men's pants pattern include:
instructions for cutting out pattern,
sewing pants with a simple fly,
sewing pants with a complicated fly,
sewing pants with extra long fly,
adapting pattern and sew pockets.